

Modelling of Five-Level Inverter for Renewable Power Source

G Vivekananda*, Saraswathi Nagla**, Dr. A Srinivasula Reddy

*Assistant Professor, Electrical and Computer Department, AXUM University, ETHIOPIA,

** Assistant Professor, Electronics & Communications Engineering, CMR Engineering College, Hyderabad

*** Professor & Principal, CMR Engineering College, Hyderabad

Abstract:

In this paper we propose better solution for designing five-level inverter by injecting small amount of real power from the renewable power source into the grid to consistently reduce the switching power loss, the harmonic distortion in it, and EMI in power electronic devices caused by switching operation. In order to construct we require 2 dc capacitors, full-bridge inverter, a dual buck converter and filter. Here role of dual-buck converter is to convert 2 dc capacitor voltage sources to a dc output voltage with three levels and that balances these 2 dc capacitor voltages, thus output voltage of dual-buck converter supplies to full-bridge inverter. Finally it is designed to produce output current controlled to generate a sinusoidal current in phase with utility voltage to inject to grid. We also simulated results with Matlab Simulink and studied power decoupling performance.

I. INTRODUCTION

The Demand for renewable energy has increased significantly over the years because of shortage of fossil fuels and greenhouse effect. The definition of renewable energy includes any type of energy generated from natural resources that is infinite or constantly renewed. Examples of renewable energy include solar, wind, and hydropower. Renewable energy, due to its free availability and its clean and renewable character, ranks as the most promising renewable energy resources like Solar energy, Wind energy that could play a key role in solving the worldwide energy crisis.

The common three topologies for multilevel inverters are as follows:

- 1) Diode clamped (neutral clamped),
- 2) Capacitor clamped
- 3) Cascaded H-bridge inverter.

A multilevel inverter is power conversion device that produces an output voltage in the needed levels by using DC voltage sources applied to input [3]. Multilevel inverter which performs power conversion by using the discrete DC voltage sources was firstly introduced in 1975, this multilevel inverter structure consists of the H-bridges connected in series. Then, the diode-clamped multilevel inverter was emerged. It employs the capacitors connected in series to separate the DC bus voltage in different levels. In 1992, the capacitor clamped multilevel inverter was introduced. This structure is similar to the structure of the diode-clamped multilevel inverter, but it uses the capacitors instead of the diodes to clamp the voltage levels.

Some advantages can be obtained using multilevel inverter as follows: the output voltages and input currents with low THD, the reduced switching losses due to lower switching frequency, good electromagnetic compatibility owing to lower, high voltage capability due to lower voltage stress on switches. These attractive features have encouraged researchers to undertake studies on multilevel inverter. Their driver isolations become more complicated because each extra level requires the additional isolated power source. So, the cost of the driver circuit will be increased according to the traditional single-cell inverters. Recently, some multilevel inverter structures with decreased number of switches have been developed to overcome this disadvantage

This below inverter topology uses 2 reference signals, instead of one reference signal, for generating PWM signals for the switches. Similarly both the reference signals V_{ref1} and V_{ref2} are similar to each other, except for an offset value equal to the amplitude of the carrier signal $V_{carrier}$, as shown in Fig.1.

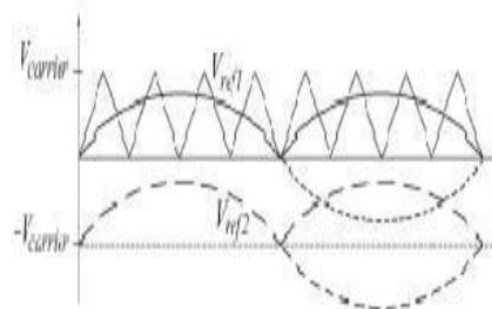

Fig.1 Carrier and reference signals

II. CIRCUIT CONFIGURATION

As conventional single-phase multilevel inverter topologies include the diode-clamped, the flying capacitor, and the cascade H-bridge types as shown in Fig. 2. Fig. 2(a) is the basic configuration of a diode-clamped multilevel inverter. Where it is configured by 2 dc capacitors, two diodes, and 4 power electronic switches.

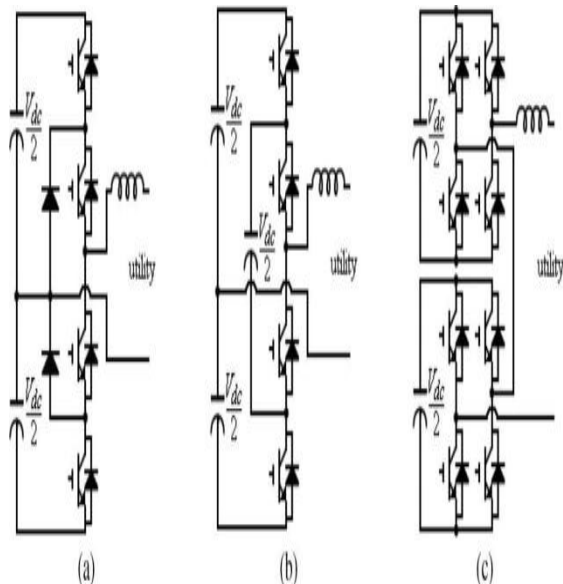

Fig 2. Circuit configuration of conventional single-phase multilevel inverter. (a) Diode clamped. (b) Flying capacitor. (c) Cascade H-bridge

Two diodes are used to conduct the current loop, and four power electronic switches are used to control the voltage levels. The output voltage of the basic diode-clamped multilevel inverter has three levels.. The control for balancing these two dc capacitors is very important

Fig. 2 (b) shows the circuit con-figuration of a basic flying capacitor multilevel inverter. As can be seen, it is configured by three dc capacitors and four power electronic switches. If five-level output voltage is required, an extra dc capacitor and four power electronic switches are required.

Fig. 2(c) shows the circuit configuration of the basic cascade H-bridge multi-level inverter. As can be seen, it is configured by two full-bridge inverters connected in cascade. However, this topology has the disadvantages that two independent dc voltage sources are required.

Figure 3 shows the circuit configuration of the five-level inverter applied to a photovoltaic power generation system. As can be seen, it is configured by a solar cell array, a dc–dc converter, a five-level inverter, two switches, and a digital signal processor (DSP)-based controller. Switches SW_1 and

SW_2 are placed between the five-level inverter and the utility, and they are used to disconnect the photovoltaic power generation system from the utility when islanding operation occurs. The load is placed between switches SW_1 and SW_2 .

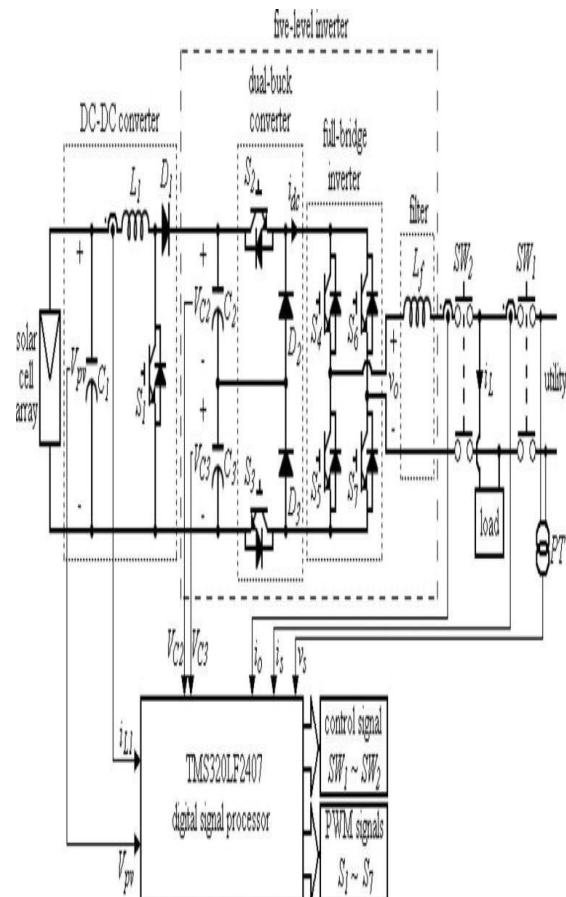

Fig. 3. Circuit configuration of the developed photovoltaic power generation system.

III. FIVE LEVEL INVERTER

The proposed multilevel inverter topology consists of the level module units. A level module unit is constructed by a DC voltage source and a bidirectional switch capable of conducting current and blocking voltage in both directions. Advantage of this switch structure is that each level module unit requires only one . It is shown that this structure consists of two basic parts. The first is the side of level module units producing DC voltage levels. The second is H-bridge topology, which generates both of the positive and the negative output voltages. isolated power supply instead of two for the gate driver. There are ten different switching states to obtain a full period of the output voltage in 5-level multilevel inverter.

SIMULATION RESULTS

To study the operation of the DPC/PWM rectifier, it is implemented in MATLAB/SIMULINK environment.

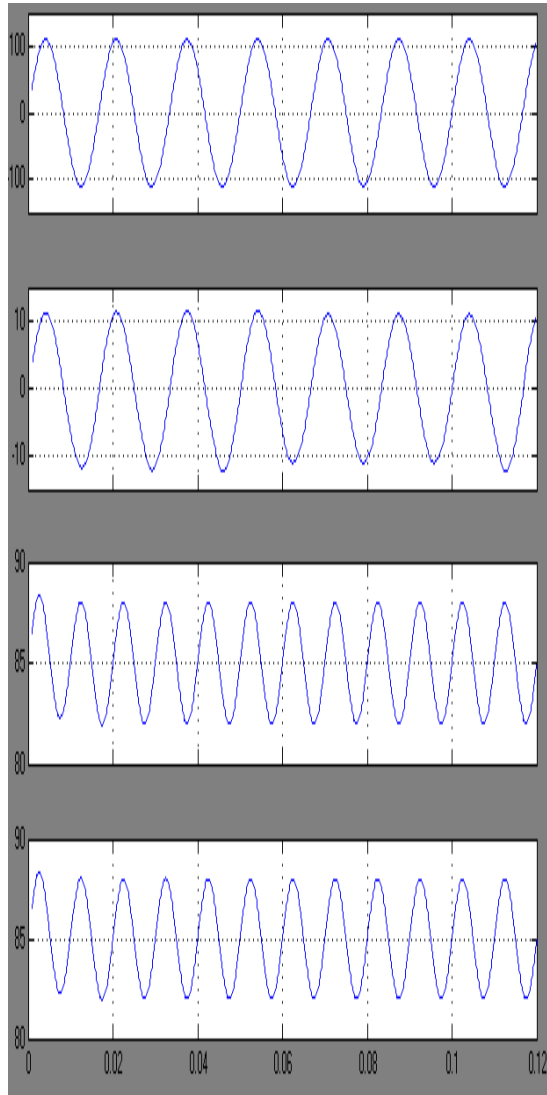

Fig. 4. Simulated results of the five-level inverter. (a) Utility voltage. (b) Output current of the five-level inverter. (c) DC capacitor voltage V_{c2} (d) DC capacitor voltage V_{c3}

Fig. 4 depicts the simulated results for the five-level inverter used for photovoltaic power generation system under the steady state condition. The output power of the solar cell array is about optimum value. As observed in Fig. 4(b), the output current of the five-level inverter is sinusoidal nature and in phase with the utility voltage.

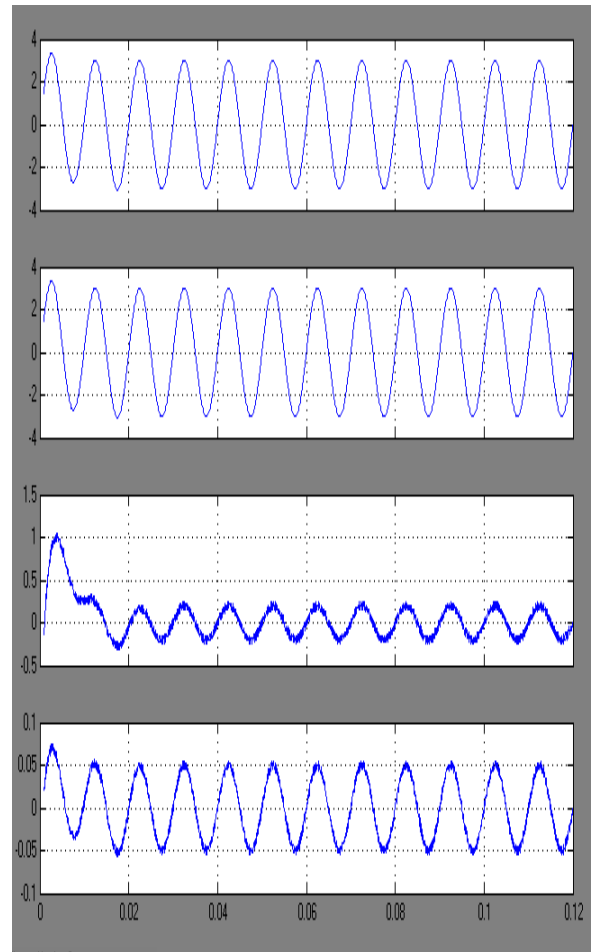

Fig. 5. Simulated for the dc-dc converter of the developed photovoltaic power generation system. (a) Voltage ripple of dc capacitor C_2 . (b) Voltage ripple of dc capacitor C_3 . (c) Output voltage ripple of solar cell array. (d) Inductor current ripple of dc-dc converter.

Likewise total harmonic distortion (THD %) of the utility voltage and the output current of the five-level inverter are 2.1% and 3.3%, respectively.

As shown in Fig. 4(c) and (d), both dc capacitor voltages V_{c2} and V_{c3} remain in balance, and it verifies the five-level inverter can outperforms the functions of converting solar power to ac power with unity power factor, low THD%, and balancing two dc capacitor voltages in effective manner.

Fig. 5. shows the simulated results for the dc-dc converter of the developed photovoltaic power generation system. Fig. 5. (a) and (b) show the peak-to-peak value of the voltage ripple at dc capacitors C_2 and C_3 . Fig. 5. (d) shows the ripple of the inductor current is very small due to the use of the current-mode control.

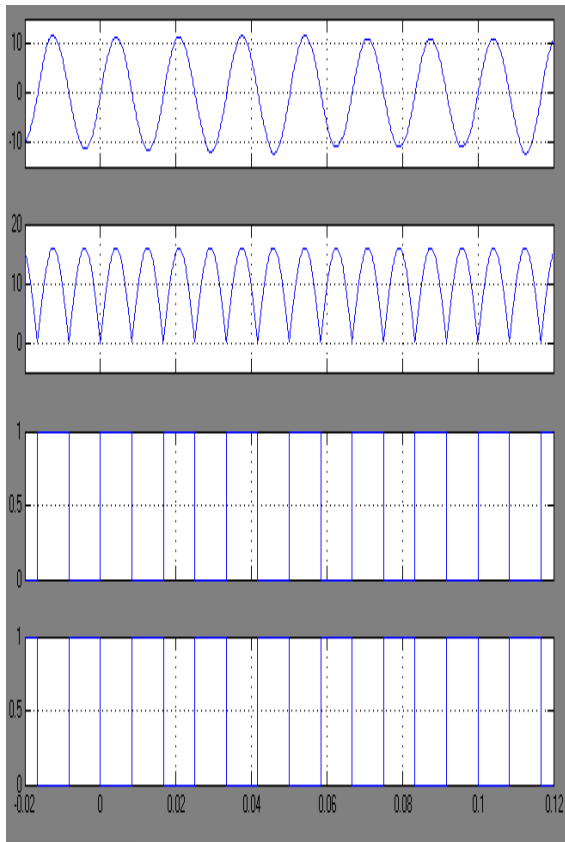

Fig. 6. Simulated results of the five-level inverter. (a) Utility voltage. (b) Output voltage of the full-bridge inverter. (c) Output voltage of the dual-buck converter.

Fig. 6 shows the experimental voltage of the five-level inverter. As seen in Fig. 6(c), the dual-buck converter outputs a dc voltage with three levels V_{dc} , $V_{dc}/2$, and 0. Fig. 6(b) shows the output voltage of the dual-buck converter is further converted to an ac voltage with five voltage level V_{dc} , $V_{dc}/2$, 0, $-V_{dc}/2$, and $-V_{dc}$ by the full-bridge inverter. The voltage variation of each level is $V_{dc}/2$. It can be verified that the five-level inverter can generate a five-level output ac voltage according to the utility voltage and only the power electronic switches of the dual-buck converter is switched in high frequency.

Fig. 7 shows the experimental results for the full-bridge inverter of the five-level inverter. As can be seen, the input current i_{dc} of the full-bridge inverter shown in Fig. 7(b) is the absolute of the output current of the full-bridge inverter shown in Fig. 7(a). As seen in Fig. 7(c) and 7(d), the switching

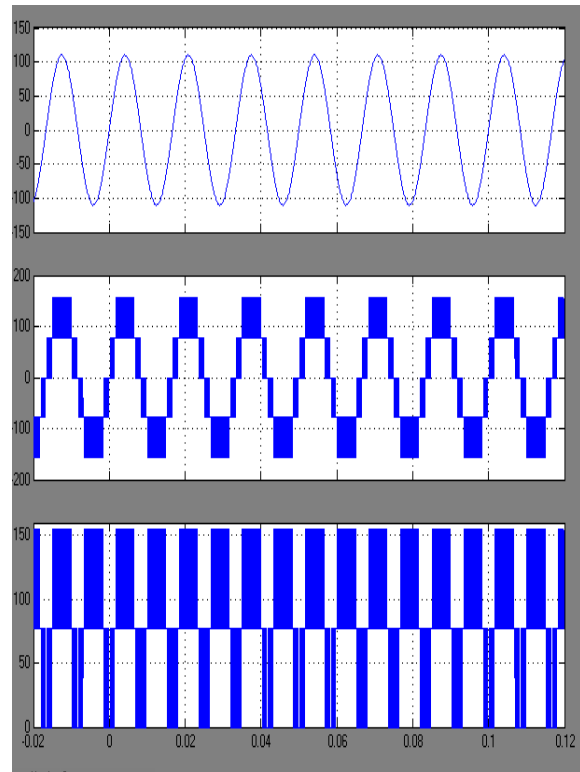

Fig. 7. Experimental results for full-bridge inverter of the five-level inverter. (a) Output current of the full-bridge inverter i_o . (b) Input current of the full-bridge inverter i_{dc} . (c) Driver signal of S_4 . (d) Driver signal of S_5 .

Frequency of the power electronic switches S_4 and S_5 is 60 Hz. This verifies the power electronic switches of the full-bridge inverter are switched in low frequency, and the full-bridge inverter can convert the dc power into ac power by commutating.

V. CONCLUSION

This paper presented a single-phase multilevel inverter for PV application. It utilizes two reference signals and a carrier signal to generate PWM switching signals. The circuit topology, modulation law, and operational principle of the proposed inverter were analyzed in detail. The simulation results verify the developed photovoltaic power generation system, and the five-level inverter achieves the expected performance.

REFERENCES

- [1]. Xiong Liu, Peng Wang and Poh Chiang Loh "A Hybrid AC/DC Microgrid and Its Coordination Control," *IEEE Trans*,
- [2]. M. E. Ropp and S. Gonzalez, "Development of a MATLAB/simulink

- model of a single-phase grid-connected photovoltaic system,” *IEEE Trans. Energy Conv.*, vol. 24, no. 1, pp. 195–202, Mar. 2009.
- [3]. K. H. Chao, C. J. Li, and S. H. Ho, “Modeling and fault simulation of photovoltaic generation systems using circuit based model,” in *Proc. IEEE Int. Conf. Sustainable Energy Technol.*, Nov. 2008, pp. 290–294.
- [4]. J. M. Carrasco, L. G. Tranquillo, J. T. Bialasiewicz, E. Galvan, R.C.PortilloGuisado, M. A. M. Prats, J. I. Leon, and N. Moreno-Alfonso, “Power-electronic systems for the grid integration of renewable energy sources: A survey,” *IEEE Trans. Ind. Electron.*, vol. 53, no. 4, pp. 1002–1016, Aug. 2006.
- [5]. V. G. Agelidis, D. M. Baker, W. B. Lawrance, and C. V. Nayar, “A multilevel PWM inverter topology for photovoltaic applications,” in *Proc. IEEE ISIE, Guimarães, Portugal*, 1997, pp. 589–594.
- [7] Y. P. Hsieh, J. F. Chen, T. J. Liang, and L. S. Yang, “A novel high step-up DC–DC converter for a micro grid system,” *IEEE Trans. Power Electron.*, vol. 26, no. 4, pp. 1127–1136, Apr. 2011
- [8] R. P. Torrico-Bascope, and L. F. Costa , G. V. Torrico-Bascope “Generation of New Non isolated High Voltage Gain DCDC Converters” *IEEE Trans. Power electron.*, 2011
- [9] Rajasekar.S, Rajesh Gupta, “Photovoltaic Array Based Multilevel Inverter for Power Conditioning”, *IEEE Trans. Power electron.*, 2011.
- [11] Surin Khomfoi1,, Chatrchai Aimsaard “A 5-Level Cascaded Hybrid Multilevel Inverter for Interfacing with Renewable Energy Resources” , *IEEE Trans.*,2012.
- [12] J. Ganesh Prasad Reddy, K. Ramesh Reddy “Design and Simulation of Cascaded H-Bridge Multilevel Inverter Based DSTATCOM for Compensation of Reactive Power and harmonics”, *IEEE Trans. Power electron.* 2012.
- [13] C. Boonmee Y. Kumsuwan “A Phase-shifted Carrier-Based PWM Technique for Cascaded H-bridge Inverters Application in Standalone PV System”, *IEEE Trans. Power electron.* 2012.